

### Australian Approvals

- This mixer complies to Australian and New Zealand Standards AS/NZS 6400.
- The mixer has 4 Star water efficiency rating under the WELS Scheme with water consumption of 7.5 liters per minute.



### 15 YEAR WARRANTY

- Fifteen (15) year warranty applies to replacement ceramic cartridge, five (5) years parts and labour starting from date of purchase of product. After five (5) years, a further additional ten (10) years replacement ceramic cartridge warranty is applicable. This extended part-only warranty is non-transferable and applies only to the original purchaser. The guarantee only applies if the mixer is installed with pressure limiting valves.
- The guarantee only applies if the mixer is installed with pressure limiting valves.
- Any faults caused by defective production will be replaced free-of-charge during the guarantee period.
- Any such faults will be replaced, at the sole discretion of Franke, either by repairing faulty components or by replacing the whole product. The Company is not liable for damage caused by: a) improper or unsuitable use and/or maintenance - b) transport - c) knocks, tampering, incorrect repairs and repairs made by unauthorised technicians - d) normal wear of components (non-return valve, membrane, etc.) and/or the use of non-original spare parts - e) non-compliance with the technical instructions - f) freezing and/or impurities in the water pipes.
- The guarantee only applies if a document proving the date of purchase is produced.
- The guarantee covers all the countries where Franke products are sold, either directly or through an authorised distributor.
- The guarantee does not cover product assembly or disassembly charges, visits and calls of specialised technicians, costs borne by the customer due to the unavailability and/or non-use of the product.
- Any imperfections in the finishes or in the natural materials used should not be considered as faults but a typical characteristic of these crafted products.
- In the case of various accessible visible components and products requiring only minor rectification under guarantee, Franke reserves the right to supply these on a "parts only" basis to the customer. Such articles may include accessories, aerators, hand sprays, hoses, handles, levers, fixings, washers and dress fittings, etc.
- 15 year warranty effective on taps sold on or after 01/10/2011.

### IMPORTANT INFORMATION

- Flush out pipe work prior to connecting your new mixer.
- All mixers to be installed with isolating stop cocks.
- Tap must be installed with pressure limiting valves.
- Mixer should be installed by a qualified plumber.
- This mixer is designed for domestic use only.
- Failure to comply will void all warranty.

For further information on Franke kitchen sinks, taps, waste management systems and accessories visit our website or contact us for your nearest retailer.

[www.franke.com.au](http://www.franke.com.au)

PR Kitchen Systems Pty Ltd

Tollfree 1300 511 072

Fax 1300 372 653

# FRANKE AZIMUT TA 7811 PULL-OUT

## FRANKE USER INSTRUCTIONS AND GUARANTEE FOR MIXERS



KITCHEN  
SYSTEMS

**FRANKE**

## Franke care instructions.

- Periodically clean the aerator filter;
- Install filter valves under the sink and periodically clean the filters;
- **DO NOT USE DETERGENTS, SOLVENTS, CHEMICAL AGENTS, ABRASIVE SPONGES, WIRE WOOL OR ALCOHOL, ETC.**, which would irreparably damage the surface of the product and ruin its appearance, sheen and matt finishes;
- **CLEAN WITH SOAPY WATER AND DRY WITH A SOFT CLOTH;**
- Dry the product after use if the water is very hard or aggressive, as it may leave deposits which would damage the surface;
- Do not install the tap when the water pressure exceeds 500 kpa (in this case pressure limiting valves are required);
- Rinse the water pipes before installing the tap.

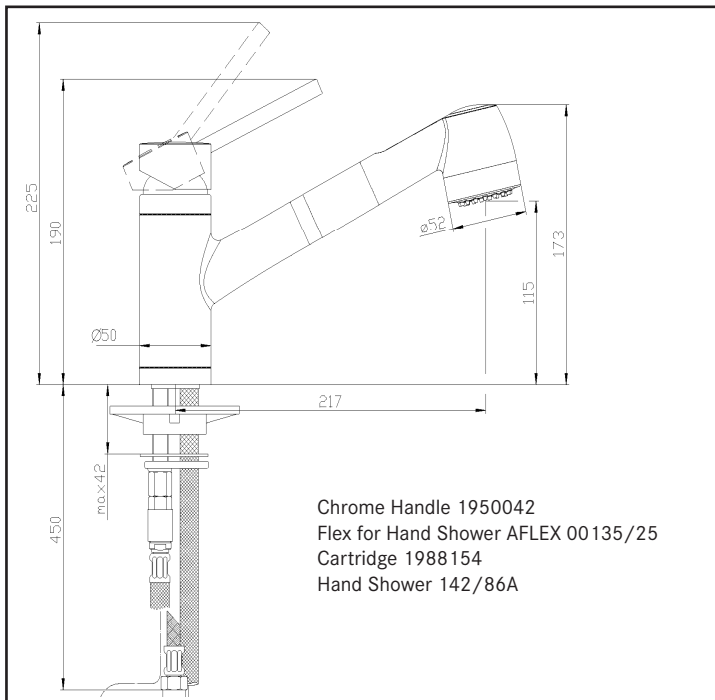

### Technical Information

- Maximum hot temperature 80° (Recommended 65°)
- Maximum operating pressure 75 psi / 500 kpa
- Minimum operating pressure 7.25 psi / 50 kpa
- Ceramic cartridge

## Franke installation instructions.

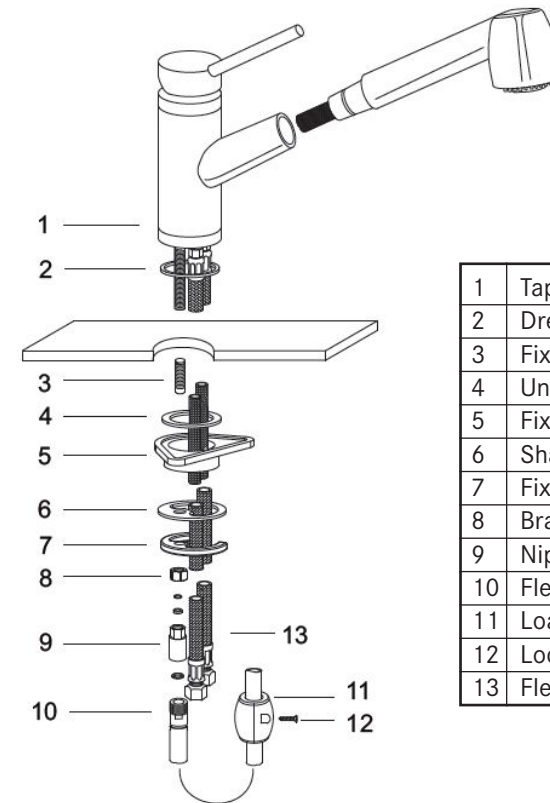

1	Tap body
2	Dress ring washer
3	Fixing thread
4	Under sink washer
5	Fixing plate
6	Shaped washer
7	Fixing plate
8	Brass fixing nut
9	Nipple
10	Flexible
11	Load weight
12	Locking screw
13	Flexible hoses

Flexible Hose  
(Aust. 203/65)

- Close the water.
- Connect the flexibles 13 (red hot water, blue cold water) to the body 1.
- Place the washer 2 over the sink hole.
- Introduce the body 1 into the sink hole.
- Introduce the washer 4 under the sink.
- Place the fixing plate 5 under the sink.
- Introduce the shaped washer 6 in the tie rod 3.
- Introduce the fixing plate 7 in the tie rod 3.
- Tighten the whole by screwing the fixing nut 8 on the tie rod 3.
- Connect the nipple 9 to the tie rod 3.
- Connect the flexible 10 to the nipple 9.
- Place the load weight 11 on the flexible 10 with the screw 12.
- Connect the flexibles 13 to the water supply-pipes or to filter taps (not included in the packaging).
- Open the water.