

AUSTRALIAN APPROVALS

- This mixer complies to Australian and New Zealand Standards AS/NZS 6400.
- The mixer has 5 Star water efficiency rating under the WELS Scheme with water consumption of 6 liters per minute.



15 YEAR WARRANTY

- Fifteen (15) year warranty applies to replacement ceramic cartridge, five (5) years parts and labour starting from date of purchase of product. After five (5) years, a further additional ten (10) years replacement ceramic cartridge warranty is applicable. This extended part-only warranty is non-transferable and applies only to the original purchaser. The guarantee only applies if the mixer is installed with pressure limiting valves.
- Any faults caused by defective production will be replaced free-of-charge during the guarantee period.
- Any such faults will be replaced, at the sole discretion of Franke, either by repairing faulty components or by replacing the whole product with the same or an equivalent model where the balance of the warranty period from the original date of purchase will take effect. The company is not liable for damage caused by: (a) improper or unsuitable use and/or maintenance (b) transport (c) knocks, tampering, incorrect repairs and repairs made by unauthorised technicians (d) normal wear of components (non-return valve, membrane, etc.) and/or the use of non-original spare parts (e) non-compliance with the technical instructions (f) freezing and/or impurities in the water pipes.
- The guarantee only applies if a document proving the date of purchase is produced.
- The guarantee covers all the countries where Franke products are sold, either directly or through an authorised distributor.
- The guarantee does not cover product assembly or disassembly charges, visits and calls of specialised technicians, costs borne by the customer due to the unavailability and/or non-use of the product.
- Any imperfections in the finishes or in the natural materials used should not be considered as faults but a typical characteristic of these crafted products.
- In the case of various accessible visible components and products requiring only minor rectification under guarantee, Franke reserves the right to supply these on a "parts only" basis to the customer. Such articles may include accessories, aerators, hand sprays, hoses, handles, levers, fixings, washers and dress fittings, etc.

IMPORTANT INFORMATION

- Flush out pipe work prior to connecting your new mixer.
- All mixers to be installed with isolating stop cocks.
- Tap must be installed with pressure limiting valves.
- Mixer should be installed by a qualified plumber.
- This mixer is designed for domestic use only.
- Failure to comply will void all warranty.

Franke has a service network in all metropolitan areas and most regional areas. Where the warranty claim has been made outside a radius of 50km from any store where the product can be purchased, the customer is responsible for the cost of delivery to the nearest service agent or the travel cost for a technician to travel to a location outside the 50km radius, unless agreed otherwise with the company.

Should you ever need to make a warranty related enquiry about your Franke product, simply call (03) 9700 9100 to speak with our friendly customer service consultants. We suggest you have the following information close at hand to make the process as easy as possible:

1. Model number of your tap
2. A copy of your original purchase receipt
3. Address details of where the tap is installed
4. Alternatively, you may email, fax or post a service request to the details provided below.

Any associated or ancillary costs to be incurred by you as a result of replacement or repair of Franke taps under this guarantee shall, in all cases, be previously approved by PR Kitchen Systems Pty Ltd. Please note: The benefits provided under this warranty are additional to other rights and remedies available to the customer under the Australian Consumer Law.

YOUR STATUTORY RIGHTS

Our goods come with guarantees that cannot be excluded under the Australian Consumer Law. You are entitled to a replacement or a refund for a major failure and for compensation for any other reasonably foreseeable loss or damage. You are also entitled to have the goods repaired or replaced if the goods fail to be of acceptable quality and the failure does not amount to a major failure.

For further information on Franke kitchen, sinks, taps, waste management systems and accessories visit our website or contact us for your nearest retailer.

www.franke.com.au

PR Kitchen & Washroom Systems Pty Ltd
83 Bangholme Road, Dandenong South VIC 3175
Ph (03) 9700 9100 Fax (03) 9700 9191

www.prkws.com.au IISTRPN109300/50#C08528 Rev. 1-05-2019



FRANKE USER INSTRUCTION AND GUARANTEE FOR MIXERS

FRANKE PESCARA 360

TA 7360 (Semi-Pro)

Chrome Tap

TA 7360MB (Semi-Pro)

Matt Black



MAKE IT WONDERFUL



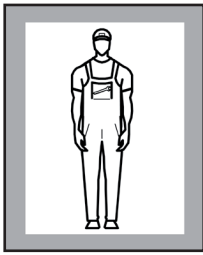

max. 80° Celsius
 max. 176 Fahrenheit
 5° - 60° Celsius
 41° - 140° Fahrenheit

1 - 5 bar
 14 - 72 psi

max. 10 bar
 145 psi

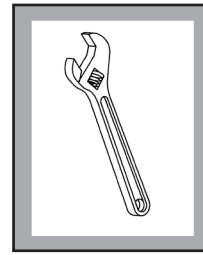
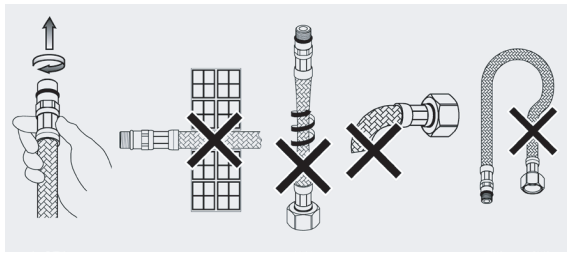

4

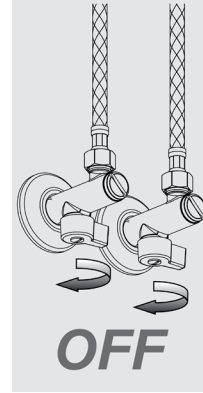

10 mm
 25 mm
 2,5 mm

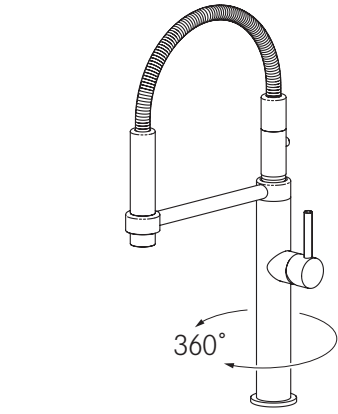

1

ø35 mm
 55 mm max

2

37 mm

1

2

400 max

3

Rmax ≥ 50 mm
 EU

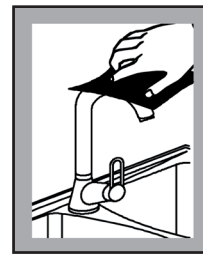

1

2